

MINIDUE

Compact volumetric proportional mechanical dosing pump for AcquaSIL 2/15[®] in disposable bags.



Apparecchiatura per il trattamento
di acque potabili certificata da



Finality

Lime deposits and corrosion are crucial problems affecting hot and cold sanitary water installations. The proportional dosage of anti-scaling and anti-corrosive products is a safe and proven technology which helps in preventing scale deposition and corrosion processes. Polyphosphates, even at very low concentrations, are able to counteract the formation of scale and corrosion in water distribution lines.

MiniDUE is a mechanical dosing pump designed for the precise and proportional dosage of AcquaSIL 2/15[®] (an aqueous solution of polyphosphates) which protects hydraulic systems and temperature exchange equipment from incrustation and corrosion. MiniDUE assures a dosage of P₂O₅ always lower than the maximum limit (5 mg/l).

Operation

MiniDUE does not need any electrical power supply. The dosage, precise and proportional in each working conditions, is started hydraulically by a mechanical system that taking advantages of the water movement introduces controlled quantities of AcquaSIL 2/15[®]. Through a mechanism known as "threshold effect", polyphosphates, even at concentration in the range of some mg/l interfere with the carbonate crystallization

phenomena hindering the formation of scale deposits. Polyphosphates also form a protective layer on metal surfaces protecting them from possible corrosion. AcquaSIL 2/15[®] is able to slowly dissolve old lime deposits restoring encrusted surfaces.

Advantages of AcquaSIL[®]



AcquaSIL 2/15[®] is an aqueous solution of food grade polyphosphates specific for drinking water treatment used for preventing scale and corrosion in hard water supply systems.

Through a mechanism known as "threshold effect", polyphosphates, if present in water at concentrations of a few mg/l, interfere with the crystallization phenomena of carbonates by hindering the formation of encrustations. Further, polyphosphates form a protective layer on metal surfaces protecting them from corrosion.

Trattare l'acqua è utile e vantaggioso

The products of the AcquaSIL® line are formulated following a rigid quality control protocol that, starting from food grade ingredients, provides a safe product.

The guarantee of a precise dosage, effective protection and, above all, the maintenance of drinking water characteristics can only be ensured by using MiniDUE in combination with AcquaSIL 2/15®.

Acqua Brevetti s.r.l. declines any responsibility arising from the use with MiniDUE of products other than AcquaSIL 2/15®.

Benefits of vacuum packaging

One of the absolute novelty of MiniDUE is the flexible recharge of AcquaSIL 2/15®. For the first time a recharge that does not require any manipulation: simply replace the bag when it is empty!

Depending on the needs, two recharging sizes are available: 250 gr and 1000 gr.

Vacuum packaging completely eliminates product contact with the operator and air dramatically reducing the risk of contamination from the outside.

The flexible bag easily fits into limited spaces (built-in boilers) that would not allow rigid tanks to be installed. The practical connection kit allows to install at a distance from the pump the flexible refill bag.

Compared to MiniDOS, the dimensions of MiniDUE have been considerably reduced and the pumping system simplified.

Innovations brought by MINIDUE

One of the main innovations of MiniDUE is its innovative flexible tank for AcquaSIL 2/15®. A liquid anti-scaling refill which does not require any manipulation of chemicals: just replace the disposable flexible tank when it is empty. Further, the flexible tank can adapt to narrow and twisted spaces which would not permit the installation of any other equipment with rigid tanks. MiniDUE is endowed with a practical connecting kit for the remote installation of the flexible tank.

Depending on needs two sizes of flexible tank are available: 250 gr and 1000 gr.

Compared to MiniDOS, MiniDUE pump housing has been greatly reduced and the pumping system has been simplified.

Key features

MiniDUE is completely self-priming. It's enough to substitute periodically the disposable refill of AcquaSIL 2/15®. A non-return valve protects MiniDUE from backpressure of the distribution network. The non return system allows to replace the disposable refill while MiniDUE is in service.

The high frequency of the injection assures a dosing homogeneity. MiniDUE doses exclusively AcquaSIL 2/15®, a combined solution of food grade polyphosphates specific for the treatment of drinking water used to prevent incrustation and corrosion in water with a temporary hardness between 5 e 35 °f. The stabilizing properties of the product AcquaSIL 2/15® are guaranteed for instantaneous temperatures up to 80° C and storage temperatures up to 60 ° C. AcquaSIL 2/15® protects new devices and hydraulic circuits and it is also able to gradually restore encrusted circuits. MiniDUE is available in two different versions: with ½”M connections (cod. PM004) with ½”F connections and DIMA connection (cod.PM005). It is also available the connection kit for the PM004 pump offline installation (code kit AV017).

Intended use, use conditions

MiniDUE has been specifically designed for the dosage of AcquaSIL 2/15® in cold and hot sanitary water but it can be used also to protect: boilers (open loop hot water), hot water makers, cold water distribution lines, open loop cooling systems, household appliances requiring hot water such as dishwashers, washing machines and others appliances.

Maintenance and duration

MiniDUE requires the periodical replacing of the disposable refill of AcquaSIL 2/15®.

MiniDUE must be included in the periodic sanitization program planned for the distribution system (who has built the distribution system is in charge of this

planning). As a consequence any time the distribution system is sanitized MiniDUE must be sanitized too.

For a proper maintenance two annual inspections are recommended.

Installation

Install in agreement with local regulations. Install only in hygienically suitable places.

MiniDUE should be installed in the cold water line upstream of the appliance (boiler, heat exchanger, etc.) to be protected. Install by-pass valves allowing to exclude it in case of need. Before the installation read the Installation Manual..

Warnings

MiniDUE requires a regular periodic maintenance in order to guarantee the potability requirements of the drinking water treated and the maintenance of the improvements as stated by the manufacturer. Keep away from direct sunlight and frost. MiniDUE should treat drinking water only. Read Performances and Technical Datasheet paragraph for operating limits. Follow the Instruction Manual. MiniDUE doses exclusively AcquaSIL 2/15[®]. Warranties on MiniDUE, its performances, the maintenance of drinking water standards immediately decay when any product other than AcquaSIL 2/15[®] is used.

Do not install MiniDUE upstream of solar boilers. The high temperatures reached in these systems can cause the rapid degradation of AcquaSIL 2/15[®] compromising its stabilization and protective properties.

Raw water

MiniDUE has been designed to treat only drinking water. Do not install in non-drinking water lines and contact Acqua Brevetti s.r.l. for further information. The dosage of AcquaSIL 2/15[®] increase the water concentration of P₂O₅. The P₂O₅ concentration in the water treated with MiniDUE is lower than 5 mg/l. This value refers to a water having, before being treated by MiniDUE, a concentration of P₂O₅ <0.05 mg/l.

Conformity and standards

MiniDUE is a product approved by WRAS and TIFQ. Acqua Brevetti s.r.l. works with a Quality System certified in compliance with the requirements of the UNI-EN ISO 9001 with certificate 501007368 issued by TÜV Italy Srl.

Endowment

The standard endowment includes: MiniDUE pump, DIMA fitting (for code PM005), 250 gr AcquaSIL 2/15[®] refill, remote installation kit, instruction manual (including the conformity declaration), warranty certification.

Performances and technical datasheet

	<i>Unità</i>	<i>PM004</i>	<i>PM005</i>
<i>Connections</i>	DN	½" M	½" F
<i>Minimum flow rate</i>	m ³ /h	0.18	
<i>Flow rate (ΔP=0.2 bar)</i>	m ³ /h	0.4	0.3
<i>Flow rate (ΔP=0.5 bar)</i>	m ³ /h	1.0	0.8
<i>Min-max water hardness</i>	°f	5 - 35	
<i>Max. instantaneous heating temperature</i>	°C	80	
<i>Max temperature for stored hot water</i>		60	
<i>250 gr refill autonomy</i>	m ³	10-11	
<i>1000 gr refill autonomy</i>	m ³	40-44	
<i>Min-max water pressure</i>	bar	1.5 - 6	
<i>Min-max water temperature inside MiniDUE</i>	°C	5 - 30	
Dimensions			
Width (A)	mm	90	58
Total height (B)	mm	92	128
Height at connection (C)	mm	58	123
Distance from ground (D)	mm	300	350
Depth (E)	mm	82	93

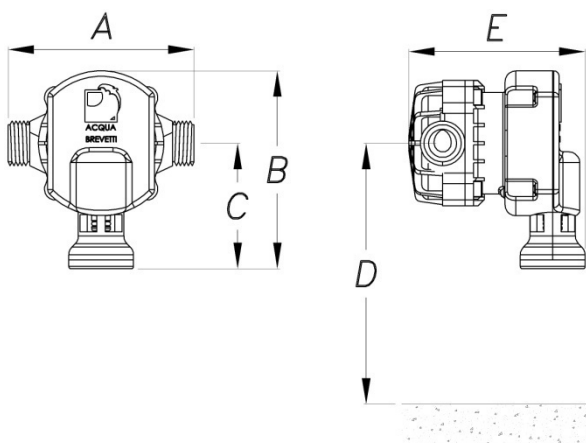

MiniDUE
cod. PM004

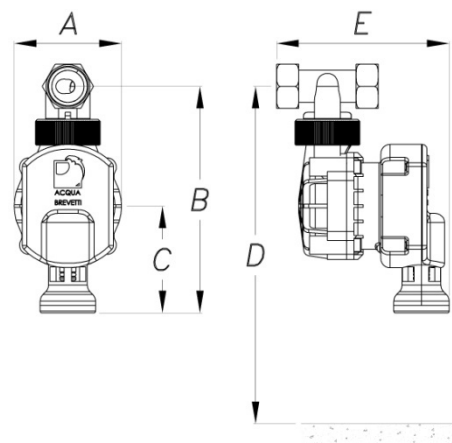

MiniDUE
cod. PM005

Installation scheme

A. Water with low to medium hardness (es. lower than 25 °f)

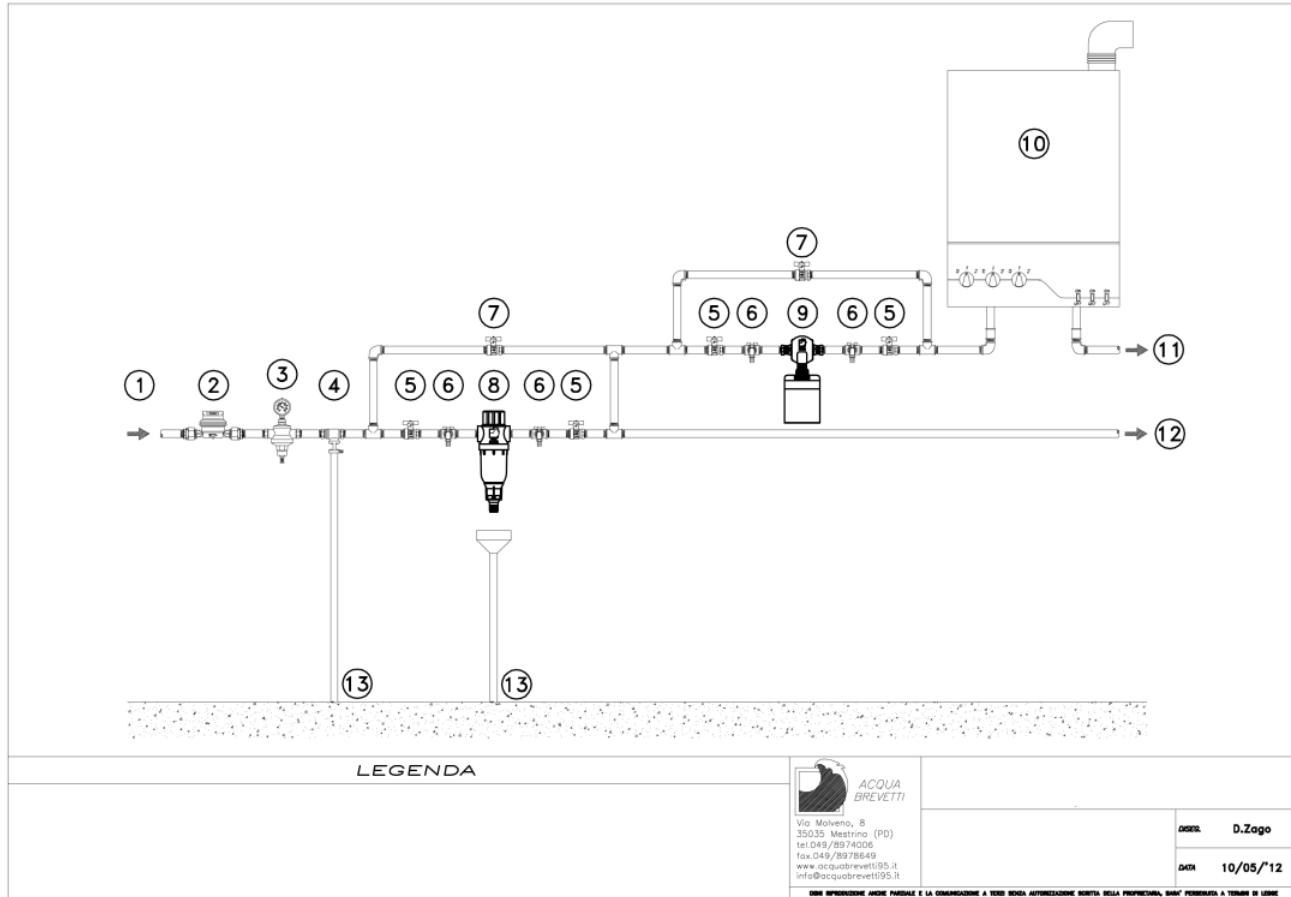

Legend

1. Water inlet • 2. Flow meter • 3. Pressure reducer • 4. Backflow preventer • 5. Shut off valve • 6. Sampling tap • 7. By-pass valve • 8. Protection filter • 9. MiniDUE • 10. Water heater • 11. Treated hot water outlet • 12. Cold water outlet • 13. Drain.



ACQUA BREVETTI SRL

APPARECCHIATURE TRATTAMENTO ACQUA
Via Molveno, 8 – 35035 Mestrino (PD)
Tel. 049/8974006 – Fax 049/8978649
e-mail: info@acquabrevetti.it
sito web: www.acquabrevetti.it



This Technical Data Sheet is based on the experiences of Acqua Brevetti s.r.l. and it applies to normal and intended use of the product as described in this sheet and in the Manual of Operation and Maintenance; any use other than those described must be communicated to Acqua Brevetti s.r.l. and authorized in writing. For the regular operation and maintenance enter into a contact with an authorized technical service center. Acqua Brevetti s.r.l. reserves the right to change and modify its products without notice. Under the current regulations it is forbidden to use and/or reproduce any part of this document which remains the sole property of Acqua Brevetti s.r.l.

Trattare l'acqua è utile e vantaggioso